

Montague Charcoal Broilers

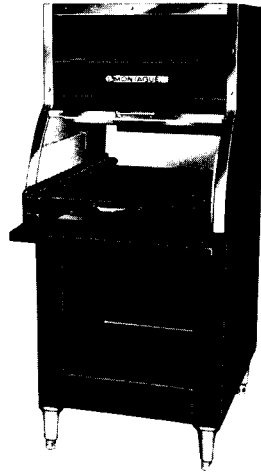

TYPICAL MODEL WITH ADJUSTABLE HOOD
(Available without hood on special order)

Specifications: Montague Charcoal Broilers

General Information: Charcoal Broiling is ideal for exhibition and production broiling during high volume, peak periods. Additional fuel for the intense heat is obtained from the drippings to totally eliminate recovery problems.

Montague's extra heavy duty French type units provide the professional chef with the ultimate in quality charcoal broiling equipment. Each broiler is produced and assembled to Montague's exacting standards. Choose from one of four sizes best suited to your volume requirements. If you feature charcoal broiled food on your menu, Montague Charcoal Broilers will be a profitable feature in your kitchen.

Hearth: Shall be of heavy steel plate with a full 2-1/2" thick heat resistant refractory.

Insulation: Improved heat-retention and longer equipment life shall be further assured by a 1-1/4" thick, high grade refractory on three sides, backed with millboard. (Insulation on model #30A shall consist of two 1/2" thick pieces of millboard on two sides with 1-1/4" thick high grade refractory at the rear of the firebox.)

Fire Box: Sides and rear shall be lined with 1-1/2" thick high grade refractory providing improved heat-retention and longer equipment life. (Sides on Model 30A lined with 1-1/4" thick high grade refractory).

Body: Shall be of heavy gauge steel, reinforced with angle iron for added strength. The sides and rear above the fire box shall be lined with high quality ceramic fiber insulation. Two-piece construction allowing separation of hearth from base.

Grid: Shall be constructed of 3/4" half round wrought iron rods spaced 1" apart with front and rear cast iron frame members for greater heat retention. Grid shall be mounted with rollers for ease of movement and shall have two positions.

Hood: Shall be adjustable and counterbalanced as an added convenience to busy chefs, so that it remains in whatever position it is placed without requiring the use of levers or locks.

Warming Shelf: Shall provide generous area for storing/heating plates and platters directly above the hood.

Installation: For use only in non-combustible locations.

Finish: Standard shall be black with nickel plated trim. Optional stainless steel finishes are available at extra cost.

- S/S Front
- S/S Left Side
- S/S Right Side
- S/S Upper Section
- S/S Lower Section

Montague Grids

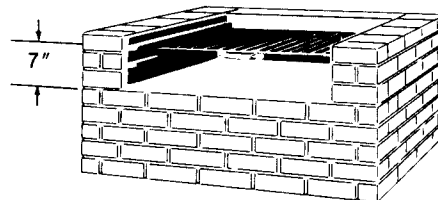

For Exhibition Broiling: The same grid and cast iron slides as incorporated in the Montague Charcoal Broilers. Available in four sizes:

PART NO.	GRID IRON		GRID SLIDES PART NO.	FIRE BOX WIDTH Δ	SLIDE LENGTH
	WIDTH	DEPTH			
1A	26"	27"	2L, 2R	27 3/16"	27 1/2"
1B	25"	31"	3L, 3R	26 5/8"	39 1/2"
1C	30 1/2"	31"	3L, 3R	32 1/4"	39 1/2"
1D	37"	31"	3L, 3R	38 7/8"	39 1/2"

Δ Fire box widths are suggested measurements to allow for expansion.

Design improvements may affect change to specifications without notice.

Commercial Cooking Equipment
Since 1857



THE MONTAGUE COMPANY • 1830 STEARMAN AVENUE, HAYWARD, CALIFORNIA 94545 • TELEPHONE 415-785-8822

Montague Charcoal Broilers

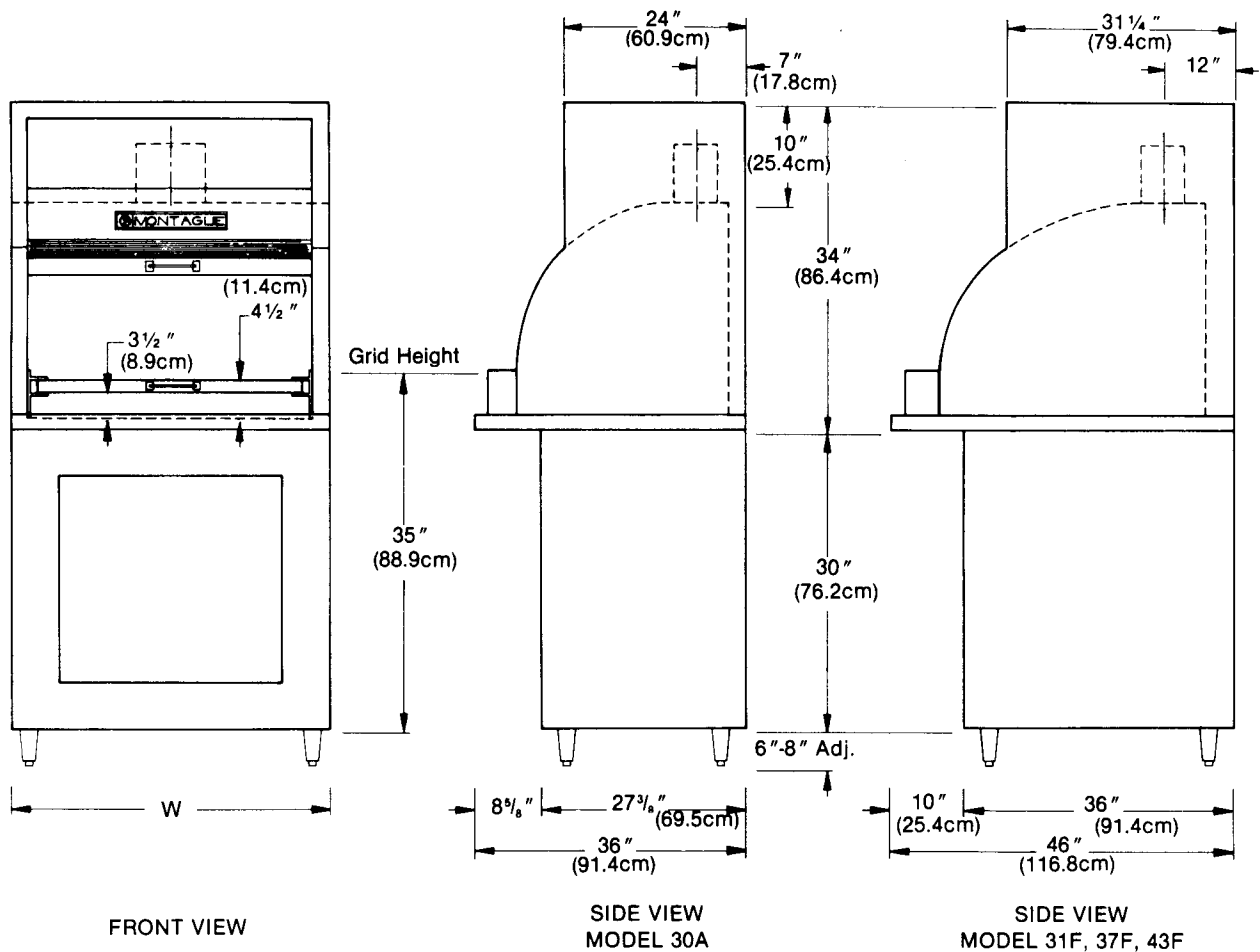

Specifications: Montague Charcoal Broilers

MODEL NO.	30A	31F	37F	43F
Grid Width	26"	25"	30 1/2"	37"
Grid Depth	27"	31"	31"	31"
Overall Width "W"	30 1/2"	30 1/2"	36"	42 1/2"
Overall Depth	36"	46"	46"	46"
Overall Height	70"	70"	70"	70"
Flue Size	8"	9"	9"	10"
Shipping Wt. Lbs.	745	1050	1080	1170
Cubic Ft., Crated	54	68	79	93

NOTE:
All models available without hood on special order.
Height from base-12 1/2". Overall height-48 1/2".

Design improvements may affect change to specifications without notice.