

MONTAGUE **GRIZZLY**

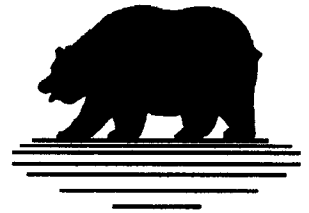

Gas Medium Duty Counter Ranges

11", 23", 34", 46", 57" & 68" wide

GC-4 and GC-3FT
Shown on 72" wide Low Boy



GENERAL

All range tops consist of multiples of 11-5/16" wide x 25" deep sections. These sections can be a combination of Open Tops, Fry Tops, Hot Tops and/or Work Surfaces. The GRIZZLY Countertop Series is practical and genuinely affordable. Precisely planned for durability, space-saving convenience and more productive countertop cooking!

MODELS:

GC — Countertop range.

GM — Countertop range on optional Modular Stand.

STANDARD FEATURES

All Counter Ranges

- Each burner has constant burning pilots for automatic ignition.
- Infinitely adjustable brass valves.
- Large, easy-grip polycarbonate handles.
- Stainless steel 4" flue riser — full width of the range.

Open Tops

- One-piece cast iron sections — each 11-5/16" wide x 25" deep.
- Two 20,000 Btu/Hr cast iron burners per Open Top section.
- Each burner has a mushroom head with spillover lip and side drilled ports to help eliminate cooking problems associated with spillovers and clogged ports.

Fry Tops, suffix FT

- 11-5/16" or 22-5/8" wide x 22" deep x 1/2" thick Fry Top.
- 34", 45-5/16", 56-5/8" and 68" wide x 22" deep x 3/4" thick Fry Tops.
- One 20,000 Btu/Hr even heat cast iron burner per 11-5/16" of Fry Top width.
- Does not require "breaking in".
- Adjustable bolts control forward pitch.
- Internal grease receptacle.
- Manually controlled.
- Located on *right*. Must specify Fry Top on left side when desired. NOTE: Fry Top on left requires external grease receptacle. Add 2-1/2" to overall width. Add suffix "L" to model number.

STANDARD FEATURES, cont.

Hot Tops, suffix HT

- 11-5/16" wide x 25" deep x 3/8" thick steel plates.
- One 20,000 Btu/Hr even heat cast iron burner per Hot Top section.

Work Surfaces, suffix WS

- Stainless steel one piece sections are 11-5/16", 22-5/8" or 34" wide.

FINISH

Standard black. (Includes S/S guard rail, valve panel and 4" high flue riser.)

OPTIONAL, (*extra cost): S/S 2 sides





OPTIONS, *(extra cost)

- HOT TOP — suffix -1HT thru -8HT.
- WORK SURFACE, S/S — (In-lieu-of open burners). Suffix -1WS thru -6WS. Must specify location.
- FRY TOP ON LEFT — (add 2-1/2" OA width):
 - Suffix -FTL — Manual control
 - Suffix -FTTL — Thermostat control
- EXTRA THICK FRY TOP:
 - 3/4" plate, 11-5/16" wide 3/4" plate, 22-5/8" wide
 - 1" plate, 22-5/8" wide 1" plate, 34" wide
 - 1" plate, 45-5/16" wide 1" plate, 56-5/8" wide
 - 1" plate, 68" wide
- THERMOSTAT FOR FRY TOP — suffix -FTT:
 - One for 11-5/16" wide One for 22-5/8" wide
 - Two for 34" wide Two for 45-5/16" wide
 - Two for 56-5/8" wide Two for 68" wide
- 4" S/S SIDE SPLASH GUARD — Removable:
 - left right both sides
- GREASE RECEPTACLE — (1 extra for 5FT, 6FT. 2 total.) External mount — adds 2" OA width.
- LEGS, 4" S/S — With mounting kit. Adjustable feet for leveling.
- MODULAR STAND — with 4-1/2" high base and 22-1/2" high S/S legs. (GM)
 - S/S front S/S front & 2 sides



MODEL DESIGNATIONS Specify Model No.'s. From Left To Right.
Example: GC -2 -1HT -3FT

Range Tops:

 Open Tops Suffix -2, -4, -6, -8, -10, -12	 Fry Tops Suffix -1FT thru -6FT	 Hot Tops Suffix -1HT thru -6HT	 Work Surfaces Suffix -1WS thru -6WS
--	---	---	--

Standard Model No.s, Total Btu/Hr, Shipping Weight, (Lbs.) & Approx. Cu. Ft. (crated):

GC-2 40,000 76 4	GC-4 80,000 162 9	GC-2-1FT 60,000 162 9	GC-2FT 40,000 173 9	GC-6 120,000 201 14	GC-4-1FT 100,000 258 14	GC-2-2FT 80,000 230 14	GC-3FT 60,000 298 14	GC-8 160,000 282 16	GC-6-1FT 140,000 298 16	GC-4-2FT 120,000 310 16	GC-2-3FT 100,000 378 16	GC-4FT 80,000 411 16
GC-10 200,000 346 18	GC-8-1FT 180,000 363 18	GC-6-2FT 160,000 374 18	GC-4-3FT 140,000 443 18	GC-2-4FT 120,000 475 18	GC-5FT 100,000 507 18	GC-12 240,000 410 28	GC-10-1FT 220,000 426 28	GC-8-2FT 200,000 438 28	GC-6-3FT 180,000 506 28	GC-4-4FT 160,000 539 28	GC-2-5FT 140,000 571 28	GC-6FT 120,000 604 28

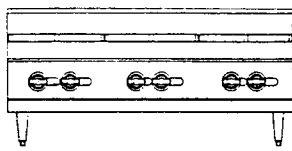

GC-6 FRONT VIEW

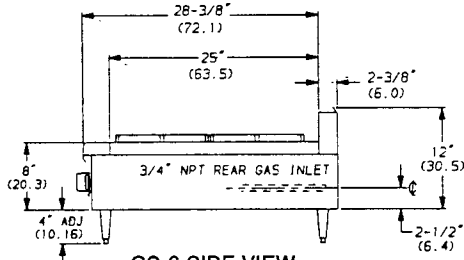

GC-6 SIDE VIEW

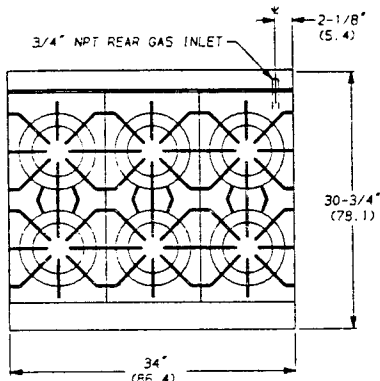

GC-6 TOP VIEW

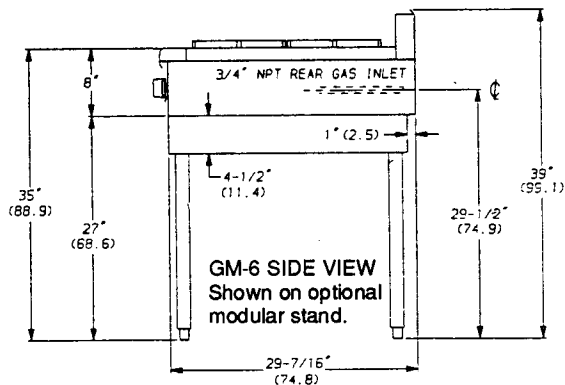

GM-6 SIDE VIEW
Shown on optional modular stand.

IMPORTANT

Commercial ranges must be installed in accordance with local codes or, in the absence of local codes, with the National Fuel Gas Code ANSI Z223.1. Compliance with codes is the responsibility of the Owner and Installer. Adequate ventilation system required. Refer to The National Fire Protection Standard No. 96, "Vapor Removal From Cooking Equipment".

Minimum Clearances:	Combustible Construction	Noncombustible Construction
GC Series: Back	2"	2"
Left & Right Side	11"	2"

Suitable for installation on noncombustible counters only.

AGA Design Certified in accordance with ANSI Z83.11 Gas Foodservice Equipment — Ranges. These appliances are intended for commercial use by professionally trained personnel.

GAS INLET SIZES: All ranges — 3/4" NPT on right rear; 3/4" NPT gas pressure regulator provided. *Regulators must be installed when appliance is connected to gas supply.*

TYPE OF GAS: Fixed orifices for use with manifold pressure of 6.0" W.C. for Natural gas, and 10.0" W.C. for Propane gas.

Note: Specify type of gas Natural Propane
Specify elevation if installing above 2000 feet.

ENTRY CLEARANCE, (All Models): 12" (uncrated)

Montague's continued commitment to quality/product improvement can cause specification and design changes without prior notice.

